

HGA9 PRO 系列舞台电动葫芦

HGA9 PRO SERIES STAGE ELECTRIC CHAIN HOIST





型号/MODEL: HGA9 Pro 2000

起升速度/LIFTING SPEED: 6 M/MIN

起升重量/SAFE WORKING LOAD: 2000KG

 制造商: 河北怀鸽起重机械集团有限公司

 地址: 河北省保定市清苑区东吕怀鸽工业园区

 Manufacturer: HEBEI HUAIGE HOISTING MACHINERY GROUP CO.,LTD

 Email: export@huaigegroup.com

 电话: 0312-8151581

 传真: 0312-8152866

 TEL: 0086-312-8151581

 ADDRESS: Huaige Industrial Park, Qingyuan County, Baoding City, Hebei Prov. China

 网址: www.huaigeqz.com

 全国免费服务热线: 400-632-3580

 Website: www.huaigegroup.com

CONTENTS 目录

1.产品简介	3
2.技术数据	4
2.1.标准配置	4
2.2.选装配置	4
2.3.线形图	5
2.3.产品爆炸图	7
3.电器数据	8

1.PRODUCT INTRODUCTION	3
2.TECHNICAL DATA	4
2.1.STANDARD VERSION	4
2.2.OPTIONAL CONFIGURATION	4
2.3.LINE GRAPH	5
2.3.PRODUCTS EXPLOSION VIEW	7
3.ELECTRICAL DATA	8

产品简介

- 吊钩合金钢锻造，设有防脱钩装置，吊钩可360度旋转。
- 采用36V低压控制和逆向保护装置，当电源接线错误时，控制电路无法动作。
- 电机采用铝合金拉伸外壳，散热功能强大，防护等级IP55。
- 独立的电磁刹车，断电后第一时间放开，刹车抱死，安全可靠。
- 内置式离合器,当超过额定载荷时使马达空转，防止超载及超载给葫芦本体和链条带来的损害。
- 完全油谷润滑,使操作更顺利，让操作更安静。



Product Introduction

- 360° swivel hook made of forged alloy steel. Anti-detaching device is equipped.
- 36V low voltage control circuit and reverse phase protection device. Once if the power lines connection is wrong, the control circuit will not work.
- Stretched aluminum outer shell with IP55 protection grade. good heat dissipation.
- Independent electromagnetic brake. It will lock the brake immediately when power source is off.
- Built-in clutch for electric motor idle rotating when it exceeds the rated payload capacity. No damage to the hoist body or chains caused by overload.
- Fully oil lubricated for quiet and smooth operation.

标准配置:

- 设备型号: HGA9 Pro 2000
- 起重量: 2000 Kg
- 提升速度(m/min): 6
- 供电电压: 220-440V、3ph、50/60Hz (见图5,P9)
- 控制电压: 36V 低压控制
- 供电电缆: 1m电源线, 带CEE-16A/4芯
- 链条尺寸 EN818-7(mm): 10*30
- 链条重量(Kg/m): 2.2
- 链条等级: G80
- 链条表面: 磷化 (黑)
- 链条行数: 1
- 导链器: 带有5个链窝链轮的精密导链器
- 链条袋: 1纺织链条袋, 可拆卸, ≤30米
- 满载噪音(dB): ≤65
- 制动器: 1个交流制动
- 吊钩: 1个下(可旋转)
- 悬挂方式: 吊钩悬挂
- 安装方式: 固定
- 塑料手柄: 无
- 防护等级: IP55
- 不含链条的重量(kg): 88.5
- 电机功率(KW): 3
- 电流消耗(A): 7
- 机械等级/FEM9.511: 1Bm/25%ED
- 限位方式: 上下电子触点限位
- 颜色: 黑色, 色号RAL 9005 哑光

选装配置:

- **编码器选装** 安装增量式编码器或预留编码器安装位 (低速链轮输出轴或高速电机轴)
- **控制手柄选装** 低压4位开关
- **称重检测选装** 称重传感器
- **链条表面处理选装** 镀锌 (白)
- **高压控制选装** 一条高压主电源控制

Standard Configuration

- Model : HGA9 Pro 2000
- SWL acc. : 2000 Kg
- Lifting speed (m/min) : 6
- supply voltage :
220-440V、3ph、50/60Hz (See Figure5,P9)
- Control voltage: 36V low voltage control
- Power supply cable : 1m power supply cable, CEE-16A/4 cord
- Chain acc. EN818-7 (mm) : 10*30
- Chain net weight (Kg/m) : 2.2
- Grade of chain : G80
- Chain surface : Parkerized (black)
- Chain falls : 1
- Chain Guide : Precise chain guide with 5-pocket chain wheel
- Chain bag : 1 textile chain bag, detachable, ≤30 meters
- Full load noise level (db) : ≤65
- Brake: 1AC brake
- Load hook: 1-down / turnable
- Suspension: Swivel hook
- Mounting position: stationary
- Plastic handles: without
- Protection level: IP55
- Weight without chain (kg): 88.5
- Motor power (KW) : ca.3
- Current consumption (A): ca.7
- Mechanism class /FEM9.511: 1Bm/ 25% ED
- Limit mode: Upper and lower electronic contact limit
- Color:black, RAL 9005 matt

Optional:

- **Encoder Optional** Incremental encoder or reserved encoder mounting position (low speed sprocket output shaft or high speed motor shaft)
- **Controlling handle Optional** Low voltage 4-position switch
- **Load detection Optional** Load cell
- **Chain surface treatment Optional** Galvanized (white)
- **High voltage control Optional** Install a high voltage main power supply to control

电动葫芦尺寸表/ELECTRIC CHAIN HOIST SIZE

图1/Figure 1

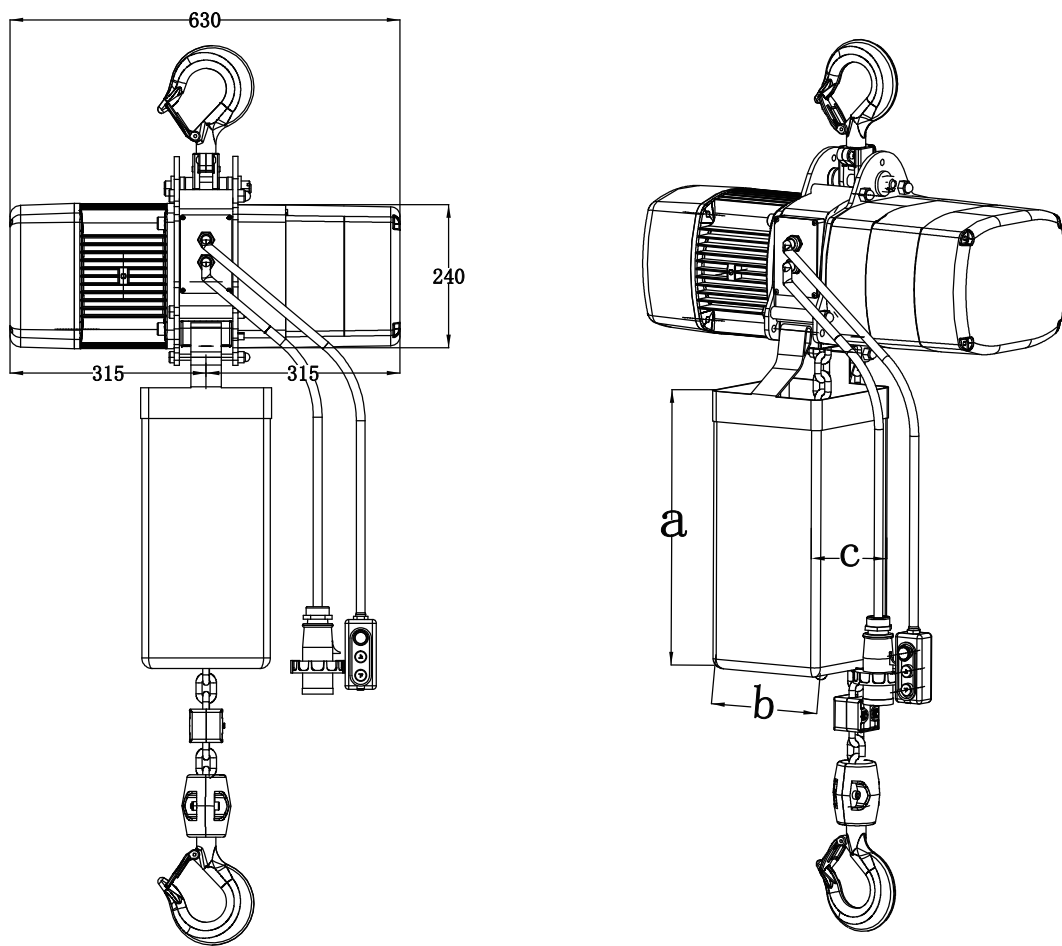

链条袋规格/CHAIN BAG SPECIFICATION			
链条长度 CHAIN LENGTH(m)	链条袋尺寸/CHAIN BAG SIZE(mm)		
	a	b	c
10	400	210	210
20	600	210	210
30	800	210	210

注：单位mm/Note:Unit mm

吊钩组件/HOOK ASSEMBLY

图4/Figure 4

上钩组件/Component of the upper hook

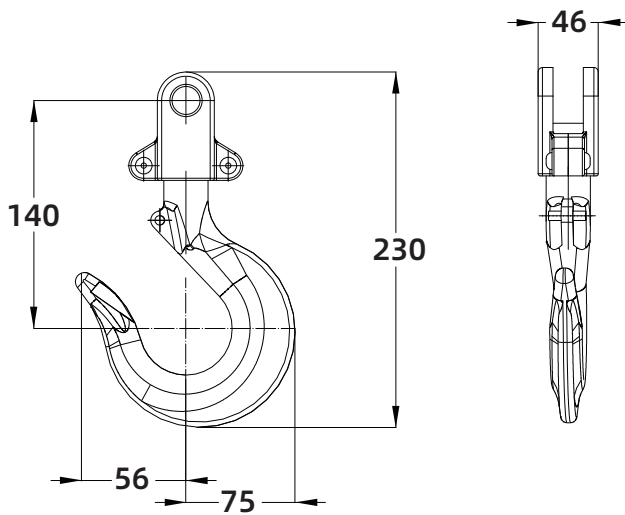

吊钩规格型号 HOOK SPECIFICATION	a1	b1	b2	d	h1	h2	B1	B2
HG-D-2T	45	11	11	59	43	38	27	26



图5/Figure 5

下钩组件/Lower hook assembly



吊钩规格型号 HOOK SPECIFICATION	a1	b1	b2	d	h1	h2	B1	B2
HG-D-2T	39	16	16	48	45	42	33	33

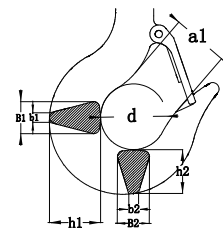
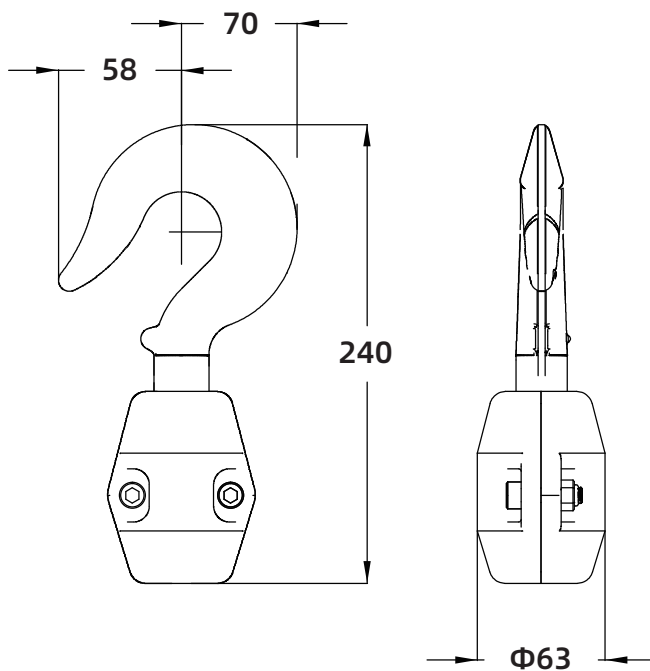
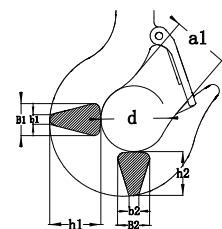

注：单位mm/Note:Unit mm

产品结构表/PRODUCT STRUCTURE

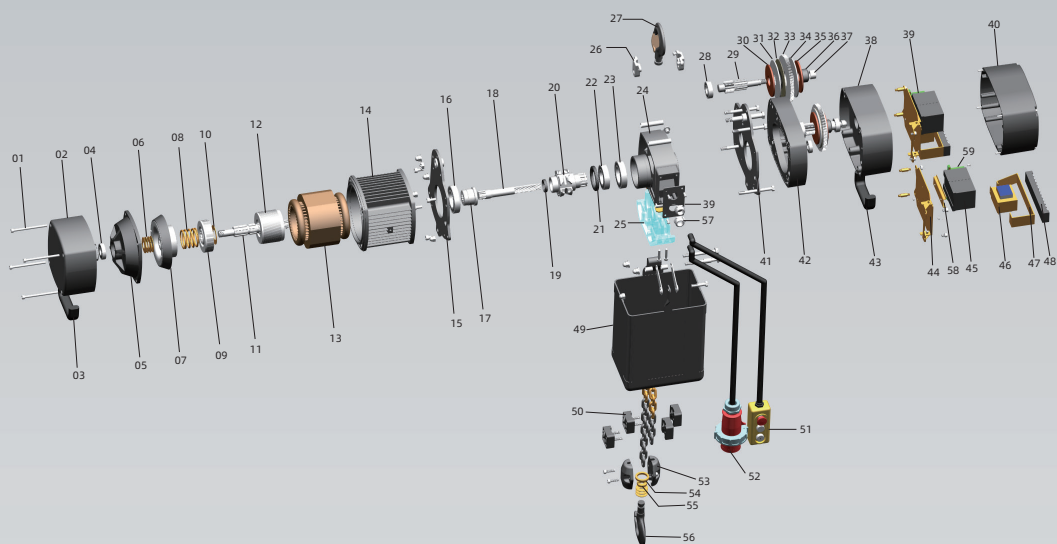

01:螺栓	02:电器盖	03:提手	04:轴承	05:刹车刷	06:上垫片
07:刹车盘	08:刹车弹簧	09:牵引块	10:大碟片	11:电机轴	12:转子
13:电机定子	14:电机箱	15:葫芦板	16:轴承	17:输出轴套	18:输出轴
19:油封	20:起重链轮	21:轴承固定圈	22:轴承	23:轴承	24:中间件
25:导链架	26:上钩夹板	27:葫芦钩	28:轴承	29:离合器轴	30:拱片
31:压片	32:摩擦片	33:离合中间齿轮	34:压片	35:拱片	36:耐磨套
37:压套	38:齿轮箱盖	39:出线口盖板	40:电器盖	41:葫芦板	42:齿轮箱
43:提手	44:安装板A9电器	45:交流接触器	46:变压器	47:安装板支架	48:接线端子
49:链条袋	50:锁关	51:手柄	52:航空插头	53:夹板	54:下钩固定圈
55:压力轴承	56:下钩	57:铜接头	58:卡轨	59:固定夹	
01:bolt	02:electrical cover	03:handle	04:bearing	05:brake cut	06:upper gasket
07:brake disc	08:brake spring	09:traction block	10:large disc plate	11:motor shaft	12:rotor
13:motor stator	14:motor box	15:hoist plate	16:bearing	17:output shaft sleeve	18:output shaft
19:oil seal	20:lifting sprocket	21:bearing retaining ring	22:bearing	23:bearing	24:middleware
25:chain guide bracket	26:upper hook splint	27:hook of hoist	28:bearing	29:clutch shaft	30:camber plate
31:pressure tablet	32:friction plate	33:clutch intermediate gear	34:pressure tablet	35:camber plate	36:wear sleeve
37:pressing sleeve	38:gear box cover	39:outlet cover	40:electrical cover	41:hoist plate	42: gear box
43:handle	44:mounting plate for A9 device	45:AC contactor	46:transformer	47:mounting plate bracket	48:connection terminal
49:chain bag	50:lockset	51:handle	52:aviation plug	53:splint	54:lower hook retaining ring
55:pressure bearing	56:lower hook	57:copper connection	58:card track	59: fixation clamp	

电器线路图/Electrical wiring diagram

低压控制-3Ph+PE/Low voltage directly control-3Ph+PE

图5/Figure 5

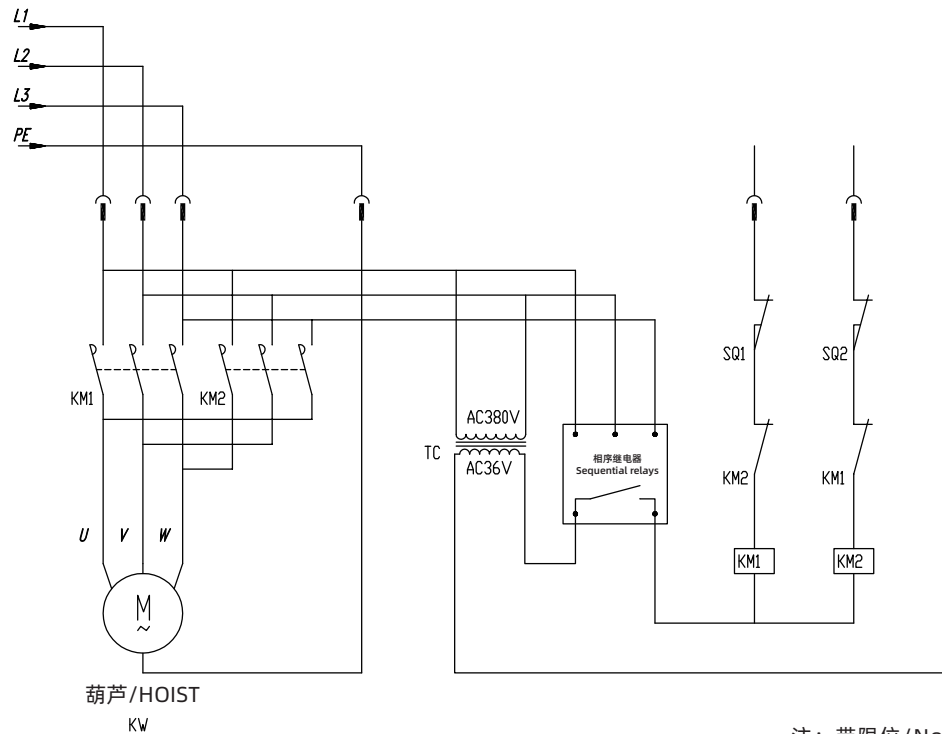

注：带限位/Note: with limit switch

高压控制-3Ph+PE/High voltage directly control-3Ph+PE

图6/Figure 6

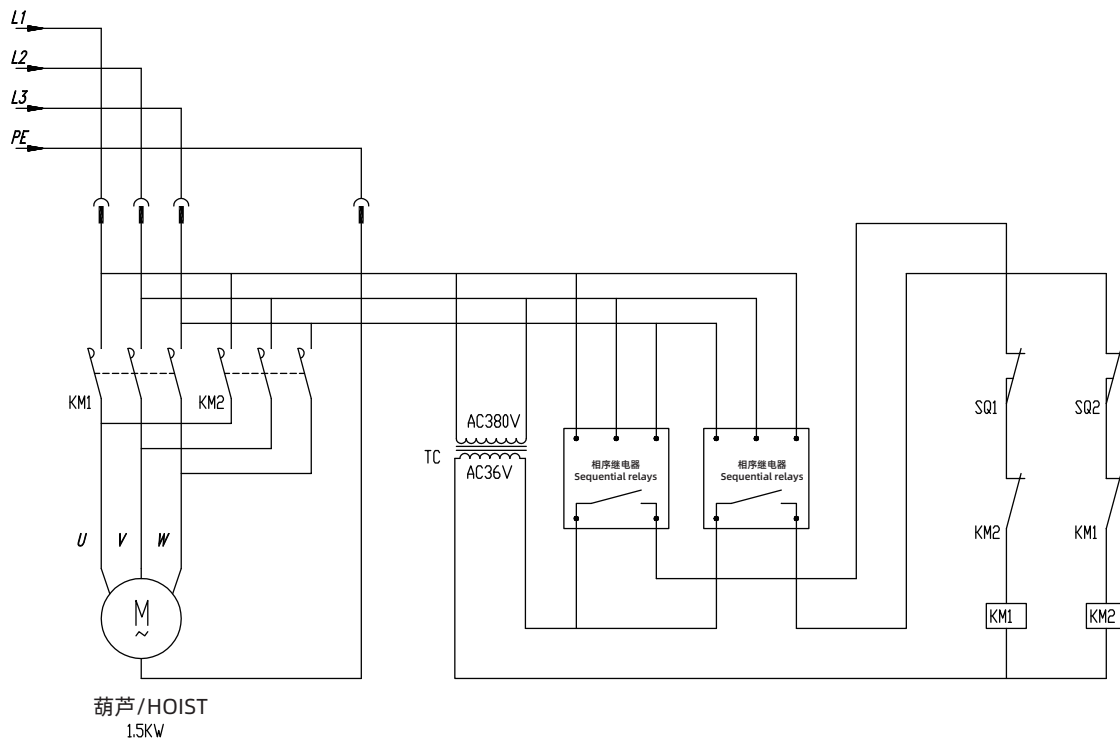

注：带限位/Note: with limit switch